

PSM 300 M



YARI OTOMATİK AÇILI TESTERE TEZGAHI SEMI AUTOMATIC MITER BANDSAW MACHINE



MALZEME SIKMA SİSTEMİ
MATERIAL CLAMPING SYSTEM



KUMANDA PANELİ
CONTROL PANEL



ŞERİT GERDİRME SİSTEMİ
BLADE TENSIONING

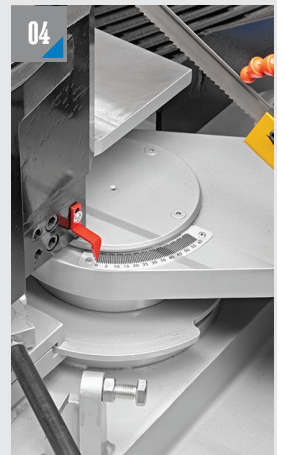

AÇILI KESİM
MITER CUTTING





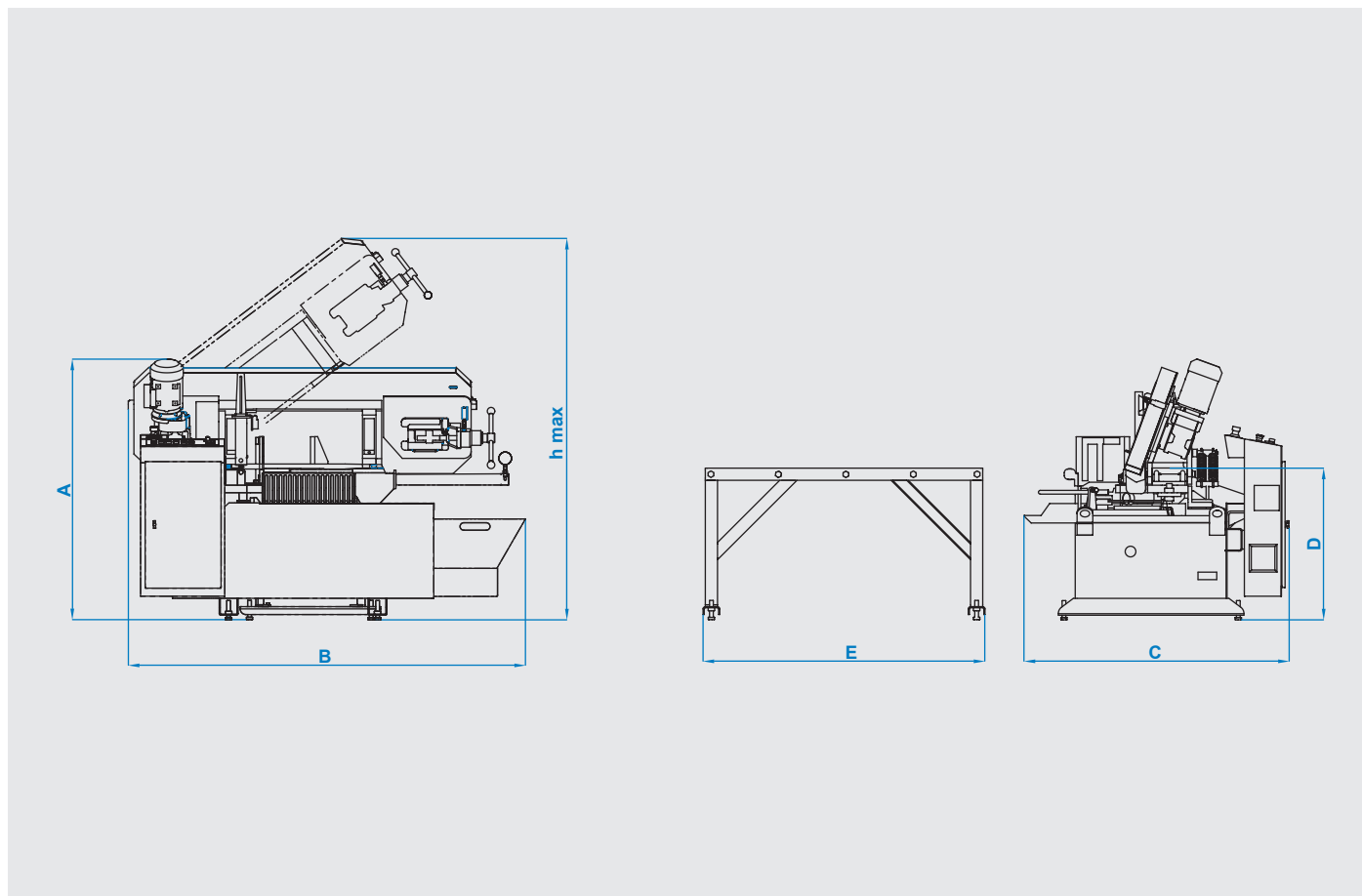



ÖLÇÜLER DIMENSIONS

MAFSALLI MODELLER PIVOT TYPES

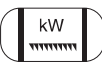
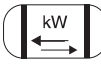
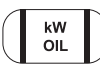
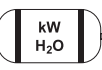

TEKNİK ÖZELLİKLER / TECHNICAL FEATURES

A	1392 mm 54.80 inch	B	2120 mm 83.46 inch	C	1415 mm 55.70 inch	D	810 mm 31.88 inch	E	1500 mm 59.05 inch	hmax	2036 mm 80.15 inch
---	-----------------------	---	-----------------------	---	-----------------------	---	----------------------	---	-----------------------	------	-----------------------

 Yarı Otomatik Semi Automatic	 Şerit Ölçüsü Blade Dimension 27 x 0.9 x 3970 mm 1 x 0.035 x 156.3 inch	 kW Şerit Motoru Blade Motor 1.5 kW - 1500 d/d 2 hp - 1500 rpm	 kW Sürücü Motor Feeding Motor Manuel Manual
 kW OIL Hidrolik Motor Hydraulic Pump Motor 0.75 kW - 1400 d/dk 1 hp - 1400 rpm	 kW H ₂ O Soğutucu Motor Cooling Liquid Motor 0.12 kW - 3000 d/dk 0.16 hp - 3000 rpm	 Voltaj Voltage 400 V 400 V	 Maksimum Güç Maximum Power 2.37 kW 3.17 hp
 Kesme Hızı Cutting Speed 15 m/dk - 100 m/dk 130 m/dk - 426 ft/min	 KG LBS Ağırlık Weight 950 kg 2094.39 lbs	 Malzeme Sıkma Sistemi Material Clamping System Hidrolik Hydraulic	 Şerit Germe Sistemi Blade Tensioning System Hidromekanik Hydramechanic

Kesim Kapasitesi Cutting Capacity		Kesim Kapasitesi Cutting Capacity		Kesim Kapasitesi Cutting Capacity		Kesim Kapasitesi Cutting Capacity		Kesim Kapasitesi Cutting Capacity		Kesim Kapasitesi Cutting Capacity	
300 mm 11.8 inch		470 mm 18.5 inch		230 mm 9.05 inch		300 mm 11.8 inch		300 mm 11.8 inch		300 mm 11.8 inch	
90°		90°		60°		45°		30°		0°	
210 x 210 mm 8.26 x 8.26 inch		210 x 210 mm 8.26 x 8.26 inch		230 x 210 mm 9.05 x 8.26 inch		220 x 220 mm 8.66 x 8.66 inch		220 x 220 mm 8.66 x 8.66 inch		220 x 220 mm 8.66 x 8.66 inch	
210 x 210 mm 8.26 x 8.26 inch		210 x 210 mm 8.26 x 8.26 inch		220 x 325 mm 8.66 x 12.79 inch		220 x 220 mm 8.66 x 8.66 inch		220 x 380 mm 8.66 x 14.96 inch		220 x 470 mm 8.66 x 18.50 inch	